



LHPEw-18/1-B-S pull cord switch up to 100 meters



Emergency pull cord switches are used to rapidly turn off conveyor belts or other large machinery and equipment by pulling the line connected to a switch. An emergency pull cord switch serves for personal protection e.g. falling on the conveyor, caught in machinery, pulling a line, etc.

The LHPEw-18/1-B-S series emergency pull cord switch is designed to be mounted between two cords. The maximum length of the cord on each side is 50 meters. Pulling on the cord will instantaneously switch the contacts in the switch off and at the same time automatically prevent accidentally switching them back on. Returning it to the neutral position is only possible by manually releasing the lock on the switch.

The 34 mm run of the switch cord minimizes accidental activation that could be caused by thermal expansion of the line, see graph.

The two SPF-W tension springs meet the requirement of ČSN EN ISO 13850 (automatic shutdown in case of a break in the line). The switch cabinet is made of colored polyester reinforced with fiberglass.

An accessory to the switch is the RL5 line and two SPF-W springs. The manufacturer does not guarantee the proper function of the switch in the event of the improper usage of the line or springs.

The LHPEw-18/1-B-S series emergency pull cord switches are manufactured with protection class I and require a protective cord run to them.

For this type, one module of switch is used with two normally closed contacts. Since it is equipped with only one contact module, it is automatically assigned the letter E – economy. The contact module does not require closing synchronization.

The switch can be connected within safety category 4.

Technical specifications:

It meets these norms	ČSN EN 60947 ČSN EN 60204 ČSN EN 60529 ČSN EN ISO 13850 ČSN EN 620
Switch track	34mm according to the spring settings for a temperature difference of up to 59°C
Force required for switching	>40N
Input for cables	2 holes M25x1.5 with plug reinforced fiberglass
Housing material	polyester
Color of housing	yellow RAL 1003
Mounting	2 longitudinal screws M10
Operating temperature	-40°C ... +85°C
Protection	class II
Number and function of contacts	2 disconnect prov. silver
Case	IP 67
Load capacity	400 VAC/6A, 230 VAC/8A, 24 VDC/10A, 80 VDC/3A
Values for the calculation of PL properties: B10 = 80,000 cycles	

Accessories for one LHPEw-18/1-B-EX switch:

Must be specified in the order, including the number of units and length, see catalog "Pull cord switches - accessories".

Tension spring	SPF-W	2pcs
Cord	RL5	* m
Tensioner	SPS6	2pcs
Eyebolts	SKA5	4pcs
Cord clamp	SKL5	8pcs
Eyelet	SH_	* pcs
Gland M 25x1.5	M 25x1.5	2pcs

* The number and length is determined from the installation documentation according to the length of the conveyor

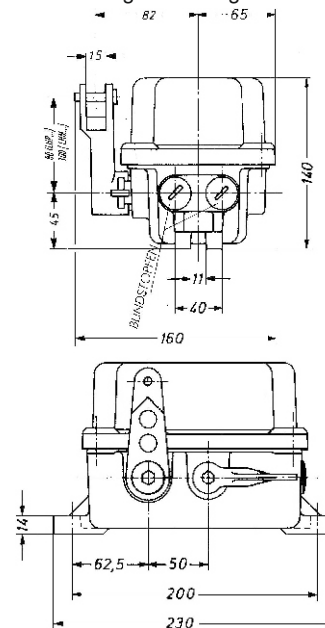

The catalogue has only those selected important parameters for your final decision. For project designs always ask for the user's guide for this product and any engineering consultation about possible uses.



LHPEw-18/1-B-S pull cord switch up to 100 meters

Function of the switch

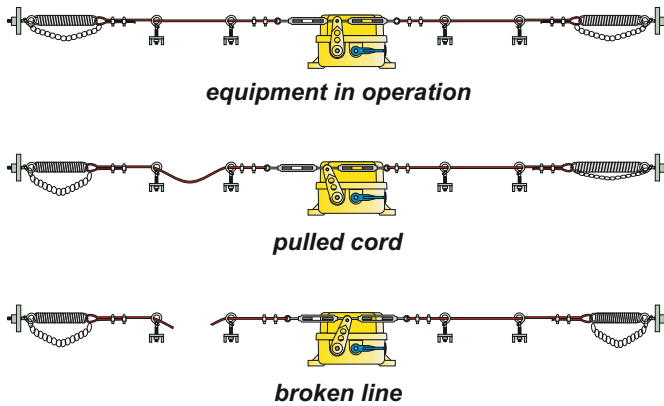

For the proper function of the switch, the tension springs must be set on both ends of the cords in an optimal position. The extent of the vertical of the chain hanging from the springs must be at least 45mm.

A change of temperature affects the length of the line and thus the suspension of the chain. For checking the settings, only a glance is necessary to determine whether the chain is properly adjusted.

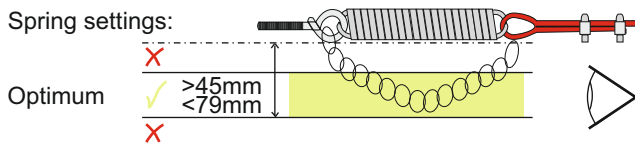

Cord switches used for an emergency stop function are installed according to the installation documentation. Installation documentation addresses the position of cord switches, calculations of the maximum length of the line depending on temperature and friction, as well as taking walking routes, mechanical stress, obstacles, dangerous places, covers, etc., into account.

In addition to the mechanical parts, the right connection must be made based on the record of categories of safety control circuits to determine how and by how much will the conveyor stop when the emergency stop switch is activated. More information is available in the catalog "Installation Documentation".

Formula for calculating the maximum cable length depending on the temperature difference and switching trajectory of the cable switch

$$L = S / (\alpha / (T_{max} - T_{min}))$$

L maximum cable length (m)
S cable switch switching trajectory (mm)
T max maximum temperature (°C)
T min minimum temperature (°C)
α thermal extension coefficient for steel α = 0.0000115/m °C⁻¹

Put the S, Tmax and Tmin values in

$$L = \frac{0.034}{S} / \alpha / (40 - (-15))$$

Result:
L = 53.754941

Warning! The length permitted by the manufacturer must not exceed 50 m at one side.

The correct position of the switch



Switch contacts

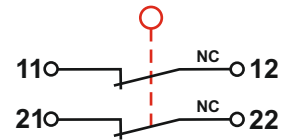

Contact A

Arrangement of contacts in the switch

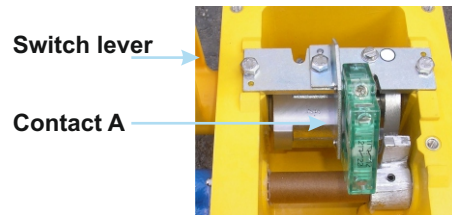

Example: The length of the cable is 43 meters. The temperature during cable installation was 10°C. This application will not affect the switch in the temperature range of -23°C to 44°C

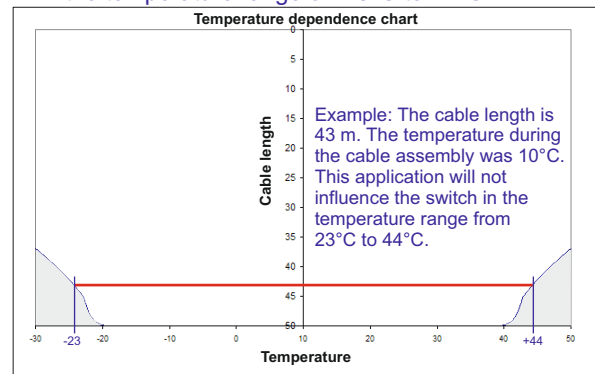

The catalogue has only those selected important parameters for your final decision. For project designs always ask for the user's guide for this product and any engineering consultation about possible uses.